



HEAT VENTILATION AND AIR CONDITIONING INDUSTRY ASSEMBLY SOLUTIONS

BUILDING TRUST



SOLUTIONS FOR BONDING, SEALING AND DAMPING OF AIR CONDITIONING SYSTEMS

Whether a structural bond or a generic sealing is needed, Sika offers a wide range of solutions suitable for the whole assembly process while satisfying the most demanding market requirements. Manufacturers of air conditioning systems rely on Sika's technologies to bond, seal and soundproof metal bodies and frames in filter systems, achieving thus cost-optimization and long-term results.

ADVANTAGES

- High load-resistant solutions
- No welding process and metal buckling
- No unaesthetic mechanical fixtures
- Sound damping
- Sealing and bonding in one step
- Improved system performance
- Reduced assembly time

PRODUCT FEATURES

- Sikaflex® and Sikasil® solutions: elastic adhesives and sealants
- Assembly performance: Sikaflex®-552 AT and Sikaflex®-953
- UV-resistant and primer-free solutions: Sikasil® AS-70 and Sikasil® AS-785
- Fungus- and mold-resistant (VDI 6022 / ISO 846): Sikaflex®-522 and Sikaflex®-953 AF
- Gap filling and short handling time with the 2-component technology of Sikaflex®-953 AF, Sikaflex®-950 and Sikasil® AS-785

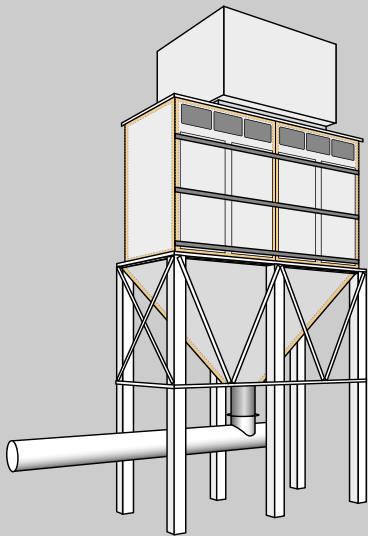

Metal frame sealed and bonded with **Sikaflex®-268**. For primer-free applications, **Sikasil® AS-70** or the fast cure **Sikasil® AS-785** are advised.

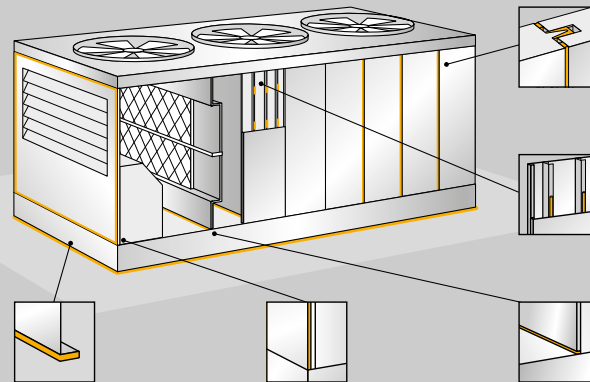

1. Joining of wall panel: **Sikaflex®-252**.
2. Bonding of wall panels: **Sikaflex®-552 AT** or **Sikaflex®-522** if hygiene requirements must be met.
3. Seam sealing: **Sikaflex®-522** or **Sikaflex®-221 RLT** fulfills hygiene requirements for HVAC systems.

5. Perimeter sealing: **SikaLastomer®-710**.
4. Structural corner bonding: **Sikaflex®-552 AT**.

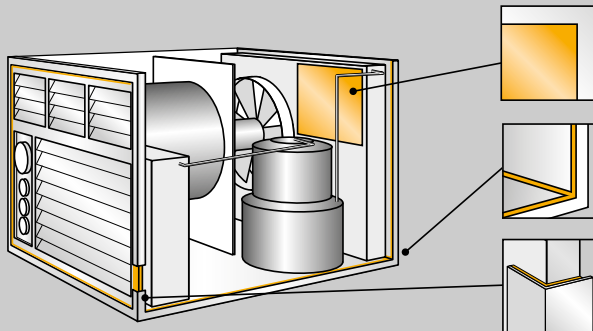

1. Vibration damping: **SikaDamp®-620**.
2. Seam sealing: **Sikaflex®-522** or **Sikaflex®-221 RLT** fulfills hygiene requirements for HVAC systems and equipments.
3. Structural corner reinforcements: **Sikaflex®-552 AT**. For faster curing, **Sikaflex®-950** and **Sikaflex®-953 AF** can be used.

SIKA SERVICES AG

Tueffenwies 16
CH-8048 Zurich
Phone: +41 (0) 58 436 40 40
Fax: +41 (0) 58 436 55 30
www.sika.com/appliances

Our most current General Sales Conditions shall apply.
Please consult the Data Sheet prior to any use and processing.



BUILDING TRUST

